

# MotorGuide® REPAIR PARTS

**Model:** ENERGY  
**BETR73V**

**SPECIFICATIONS:**

Year of Intro 2000  
Thrust 73 LBS  
Volts 24VDC  
Amp Draw 0 to 33 amps  
Mount 09 Transom  
Speeds Variable  
Fwd/Rev

**TO ORDER PARTS:**

MotorGuide Consumer Relations  
Phone 918-831-6989  
Fax 800-982-8093

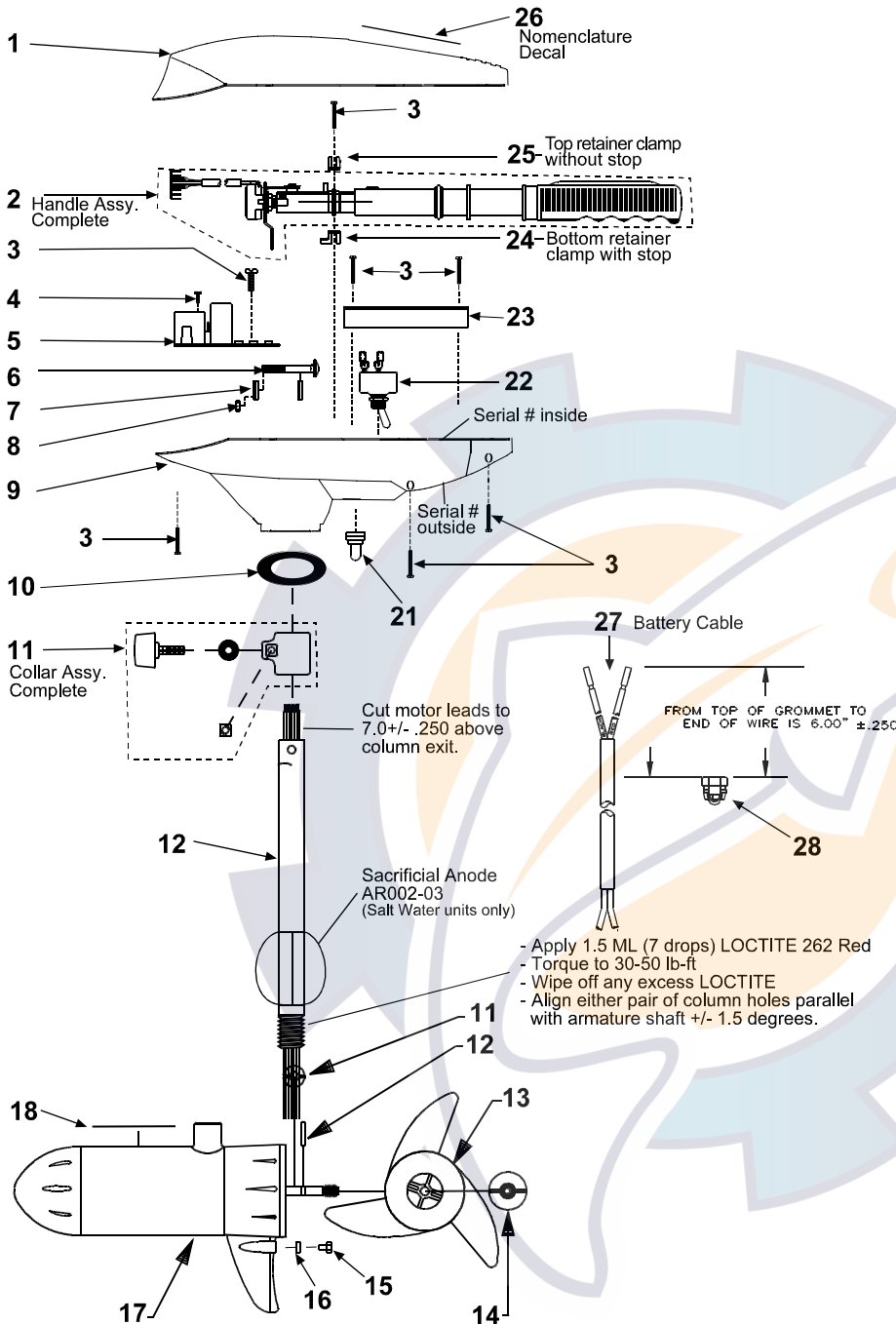

KEY	DESCRIPTION	PART #	KEY	DESCRIPTION	PART #	KEY	DESCRIPTION	PART #
1	TOP HOUSING COVER BLACK	ET053-17	12	COLUMN 36"	TT049-05	20	LOWER UNIT DECAL	ET060-07
2	HANDLE ASY	ET372-06	13	COLUMN 42"	TT049-06	21	SWITCH BOOT	FP177-01
3	#8 X 5/8 SCREW	AT141-01	14	COLUMN 50"	FR049-13	22	TOGGLE SWITCH	FP153-07
4	#4 SELF TAPPING SCREW	XT141-02	15	MONOFILAMENT WASHER	AR175-01	23	CABLE PLATE	AT155-06
5	BOARD FOR/REV	AT157-02	16	PROP DRIVE PIN	BR102-01	24	BOTTOM RETAINER CLAMP	AR036-02
6	BOLT	TT134-02	17	PROP/3 BLADE	AF124-12	25	UPPER RETAINER CLAMP	AR036-04
7	CURVED WASHER	TT171-08	18	PROP/2 BLADE	AF124-07	26	NOMENCLATURE DECAL	JT056-12
8	NYLON LOCK NUT	XT098-02	19	PROP NUT	AR099-01	27	BATTERY CABLE	XT328-06
9	T/H BASE BLACK	AT004-11			DK133-01	28	GROMMET	GR019-01
10	COLUMN SEAL	AT079-01			AR002-02			
11	DEPTH ADJUSTMENT COLLAR	AR158-01			TF397-01			

# LOWER UNIT BREAKDOWN

**Model: ENERGY**  
**BETR73V**

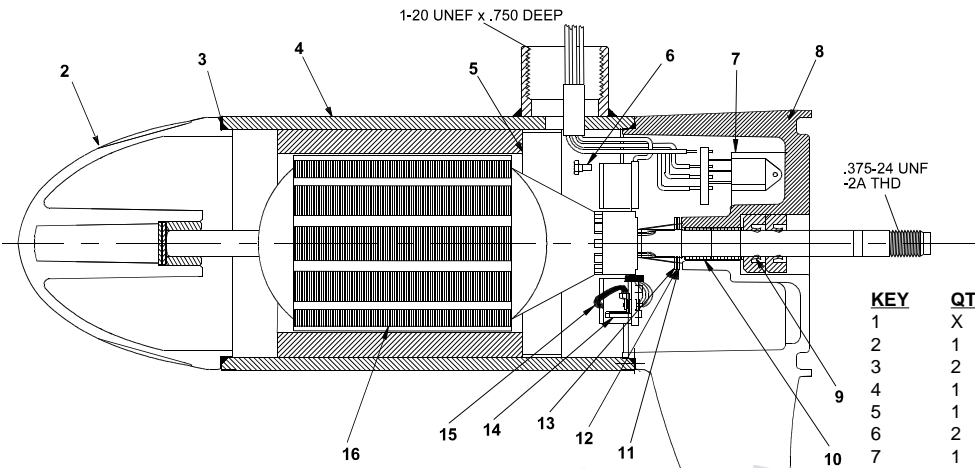

KEY	QTY	DESCRIPTION	PART NO.
1	X	MOTOR	TF397-01
2	1	NOSE CAP	XF3212-01
3	2	O RING SEAL	MR217-01
4	1	HOUSING ASY	AF3210-06
5	1	RETAINER	JF233-01
6	2	BRUSH CARD SCREW	MR228-01
7	1	DURA AMP MODULE	JF096-10
8	1	COMM CAP	XF3205-01
9	2	SHAFT SEAL	MR223-01
10	1	BEARING	MR206-01
11	1	NYLATRON WASHER	MR226-01
12	1	WASHER	MR227-01
13	1	E RING	MR219-02
14	2	BRUSH SPRINGS	XF214-01
15	1	BRUSH ASY LESS SPRING	XF3201-01
16	1	ARMATURE	TF3207-01
17	4	STATIC SEAL	MR222-01
18	4	THRU BOLT WASHER	MR216-02
19	2	DURA AMP SCREW	MR229-01
20	2	THRU BOLT	MR218-02

DIRECTION OF ROTATION IS COUNTER CLOCKWISE WHEN VIEWED FROM PROPELLER END WITH RED POSITIVE & BLACK NEGATIVE.

NOTE: TORQUE MOSFET BOLTS TO 35 TO 40 INCH LBS.

NOTE: TORQUE THRU BOLTS TO 40 TO 50 INCH LBS.

## WIRING

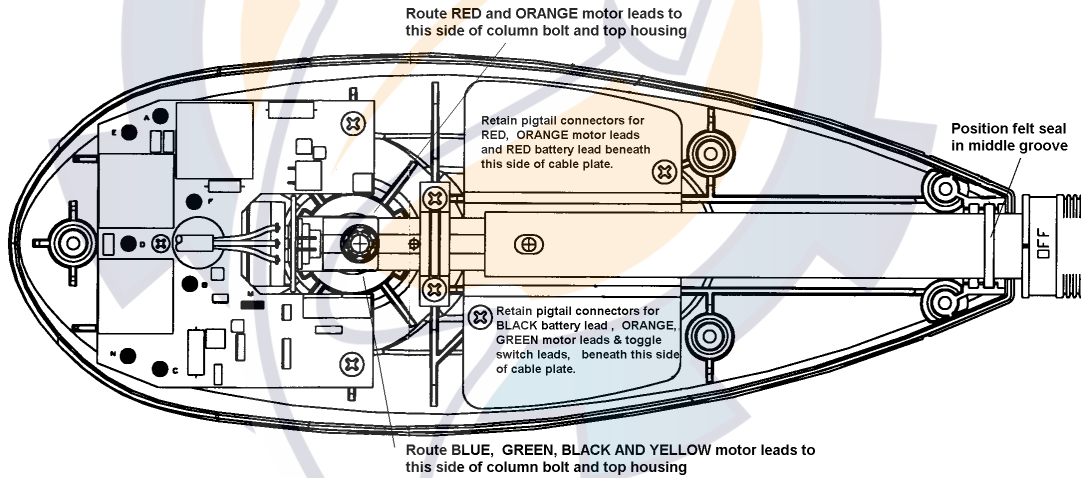

### TOP HOUSING

### MOTOR HOUSING

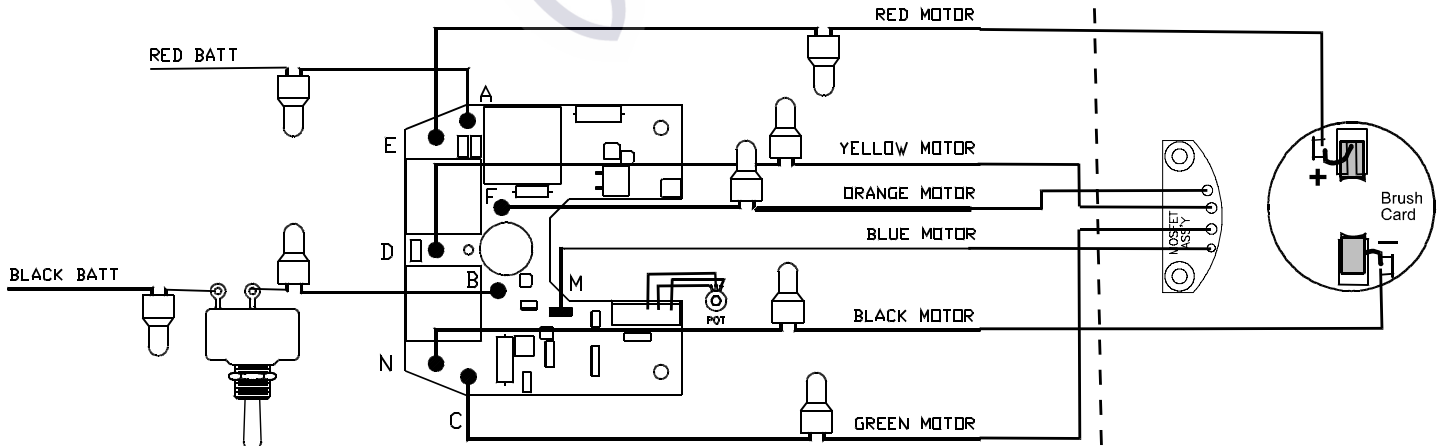

SUBJECT TO DAMAGE BY STATIC ELECTRICITY  
ASSEMBLE AT STATIC FREE WORK STATION!